

SCHEDULE 1

HARRIOTT @ ARMSTRONG CREEK STAGE 5 BUILDING ENVELOPES

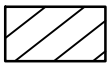
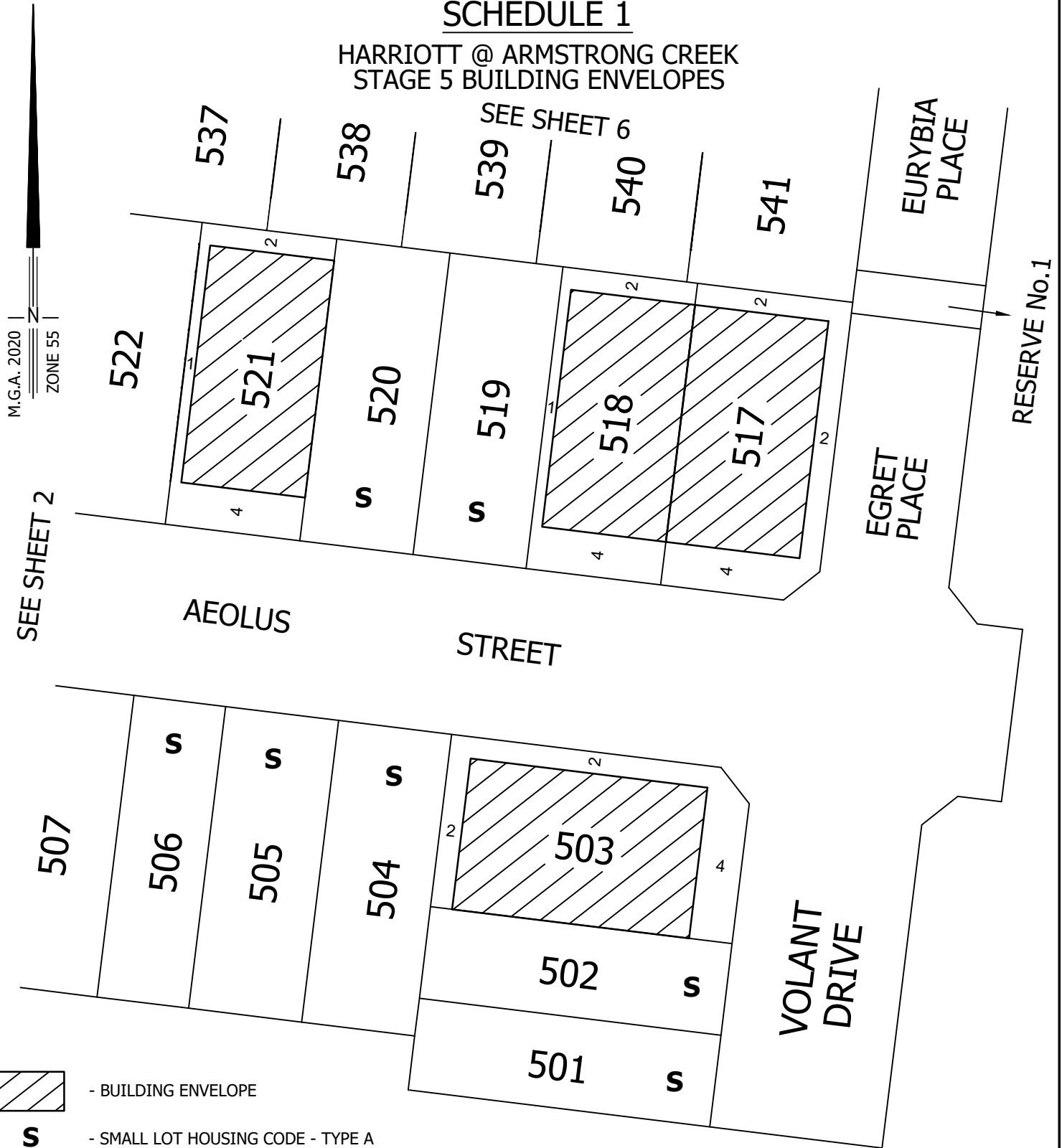

- BUILDING ENVELOPE

S

- SMALL LOT HOUSING CODE - TYPE A

- Garages are to be set back a minimum of 5 metres from the primary frontage of the allotment and 0.50 metres behind the front of the dwelling
- Balconies, verandas, open porches, covered walkways and porticos that have a maximum height less than 4.50 metres above the ground level may encroach into the front setback by 1.50 metres.
- Facade treatments and /or covered balconies or verandas on the second storey of a building that have a maximum height of less than 6.60 metres above ground level may encroach into the front setback by 1.50 metres.
- Porches, verandas, eaves, fascia, gutters and screens may encroach into the side and rear setback by 0.50 metres
- Domestic fuel tanks and water tanks may encroach into the side and rear setback by 0.50 metres
- Heating and cooling equipment and other services may encroach into the side and rear setback by 0.50 metres



MC MULLEN NOLAN GROUP
31/574 Plummer Street,
Port Melbourne, VIC, 3207
Tel: (03) 7002 2200
Fax: (03) 7002 2299
www.mngsurvey.com.au
MNG Ref : 80004be-046b

SCALE
1:500

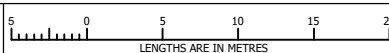

ORIGINAL SHEET
SIZE: A4

SHEET 1 OF 6

VERSION B

HARRIOTT
AT ARMSTRONG CREEK

SCHEDULE 1

HARRIOTT @ ARMSTRONG CREEK STAGE 5 BUILDING ENVELOPES

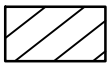
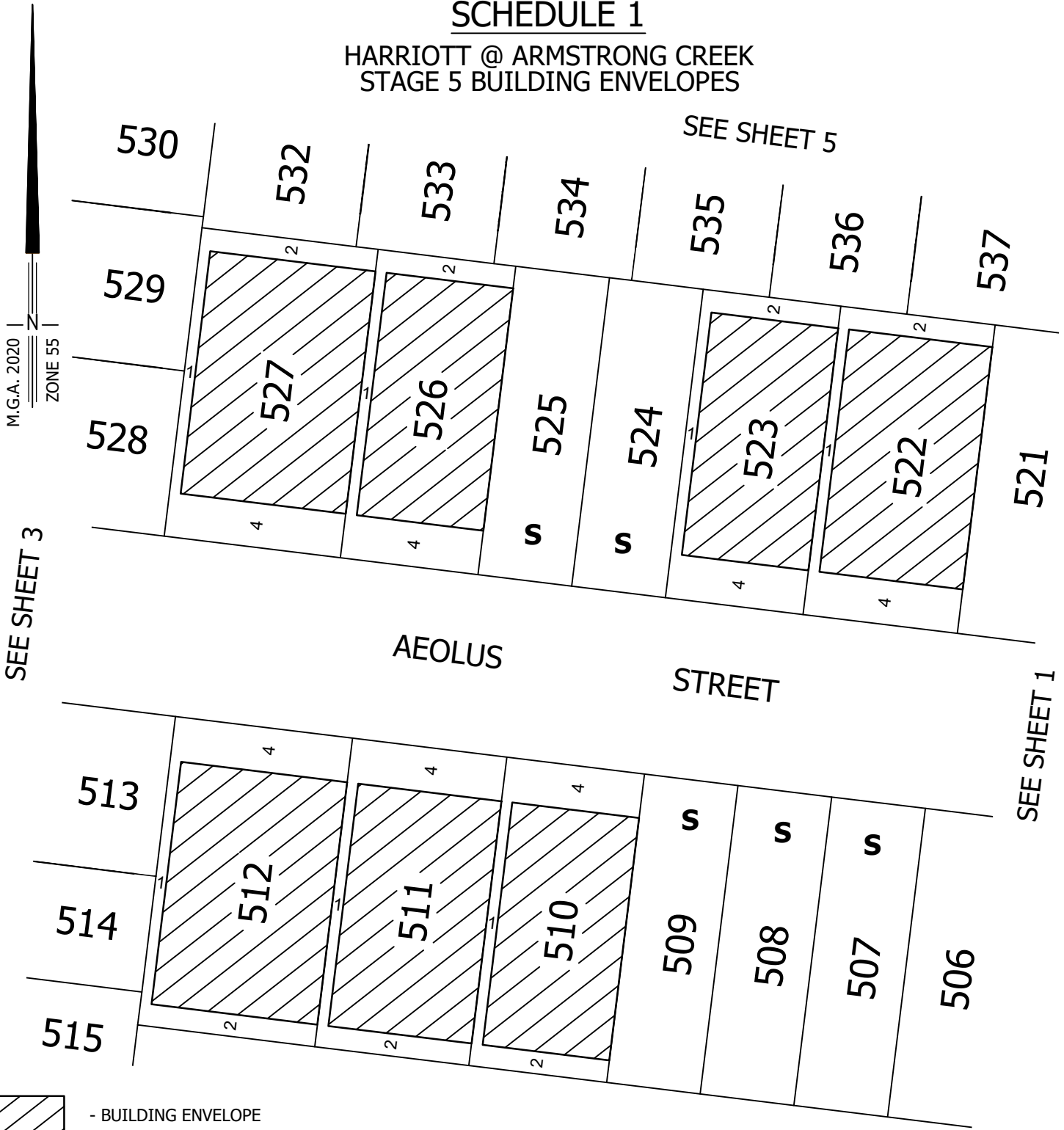

- BUILDING ENVELOPE

S

- SMALL LOT HOUSING CODE - TYPE A

- Garages are to be set back a minimum of 5 metres from the primary frontage of the allotment and 0.50 metres behind the front of the dwelling
- Balconies, verandas, open porches, covered walkways and porticos that have a maximum height less than 4.50 metres above the ground level may encroach into the front setback by 1.50 metres.
- Facade treatments and /or covered balconies or verandas on the second storey of a building that have a maximum height of less than 6.60 metres above ground level may encroach into the front setback by 1.50 metres.
- Porches, verandas, eaves, fascia, gutters and screens may encroach into the side and rear setback by 0.50 metres
- Domestic fuel tanks and water tanks may encroach into the side and rear setback by 0.50 metres
- Heating and cooling equipment and other services may encroach into the side and rear setback by 0.50 metres



MC MULLEN NOLAN GROUP
31/574 Plummer Street,
Port Melbourne, VIC, 3207
Tel: (03) 7002 2200
Fax: (03) 7002 2299
www.mngsurvey.com.au
MNG Ref : 80004be-046b

SCALE
1:500

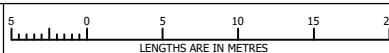

ORIGINAL SHEET
SIZE: A4

SHEET 2 OF 6

VERSION B

HARRIOTT
AT ARMSTRONG CREEK

SCHEDULE 1

HARRIOTT @ ARMSTRONG CREEK STAGE 5 BUILDING ENVELOPES

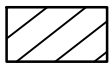
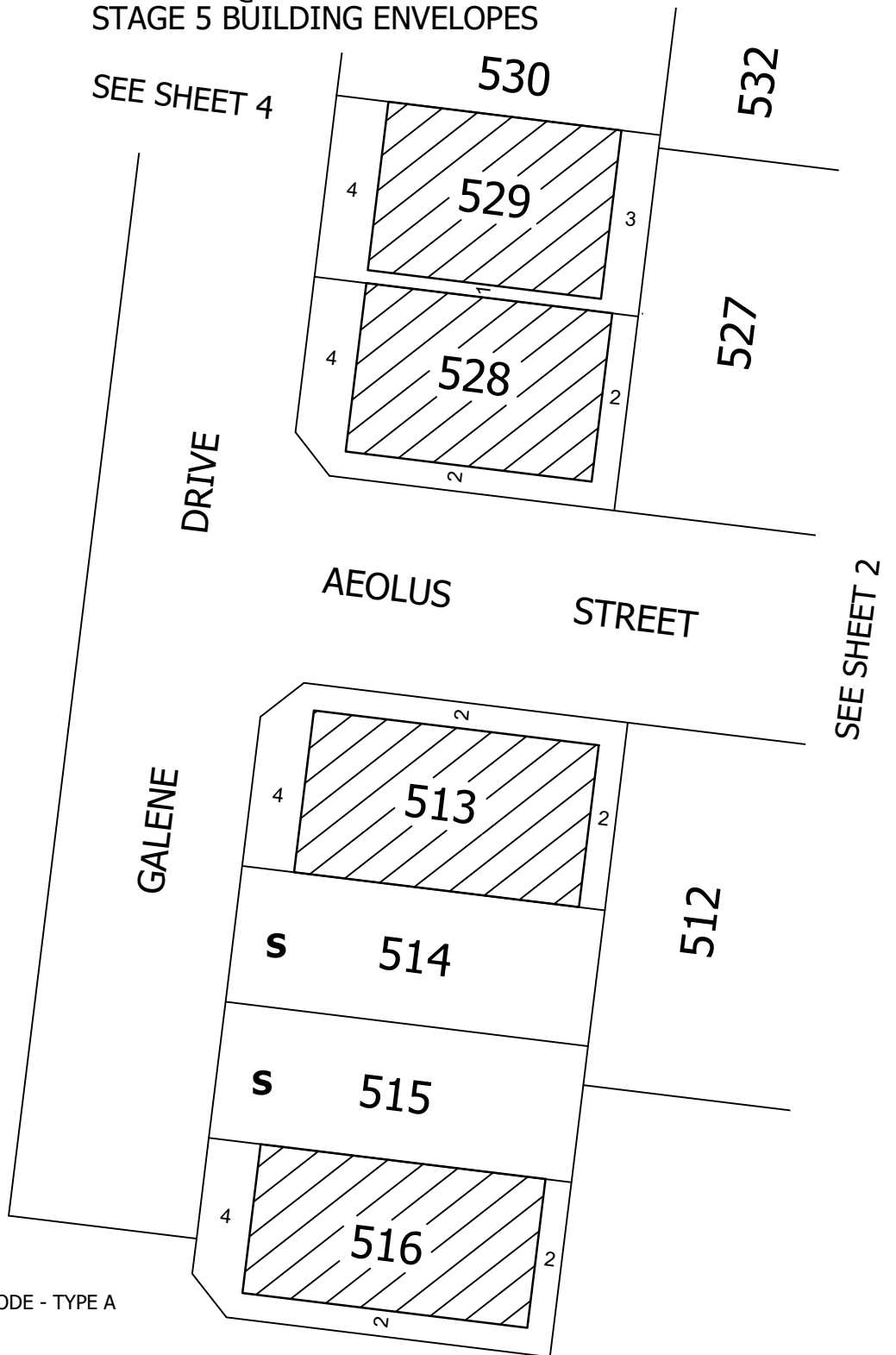
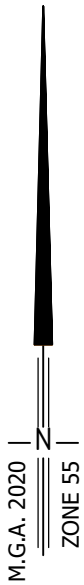

- BUILDING ENVELOPE

S

- SMALL LOT HOUSING CODE - TYPE A

- Garages are to be set back a minimum of 5 metres from the primary frontage of the allotment and 0.50 metres behind the front of the dwelling
- Balconies, verandas, open porches, covered walkways and porticos that have a maximum height less than 4.50 metres above the ground level may encroach into the front setback by 1.50 metres.
- Facade treatments and /or covered balconies or verandas on the second storey of a building that have a maximum height of less than 6.60 metres above ground level may encroach into the front setback by 1.50 metres.
- Porches, verandas, eaves, fascia, gutters and screens may encroach into the side and rear setback by 0.50 metres
- Domestic fuel tanks and water tanks may encroach into the side and rear setback by 0.50 metres
- Heating and cooling equipment and other services may encroach into the side and rear setback by 0.50 metres

SCALE
1:500

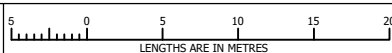

ORIGINAL SHEET
SIZE: A4

SHEET 3 OF 6



MC MULLEN NOLAN GROUP
31/574 Plummer Street,
Port Melbourne, VIC, 3207
Tel: (03) 7002 2200
Fax: (03) 7002 2299
www.mngsurvey.com.au
MNG Ref : 80004be-046b

VERSION B

HARRIOTT
AT ARMSTRONG CREEK

SCHEDULE 1

HARRIOTT @ ARMSTRONG CREEK STAGE 5 BUILDING ENVELOPES

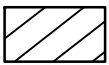
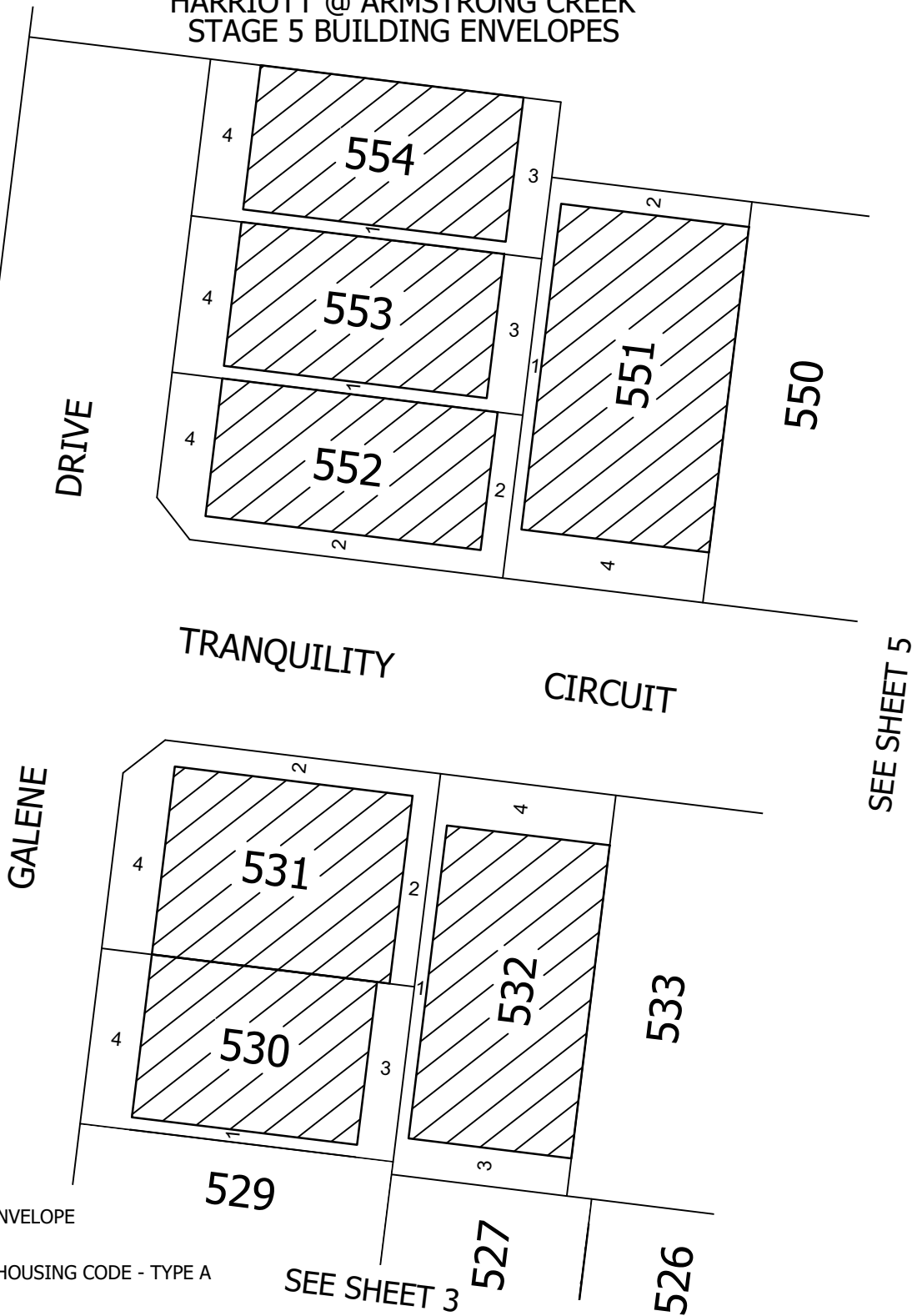

- BUILDING ENVELOPE

S

- SMALL LOT HOUSING CODE - TYPE A

- Garages are to be set back a minimum of 5 metres from the primary frontage of the allotment and 0.50 metres behind the front of the dwelling
- Balconies, verandas, open porches, covered walkways and porticos that have a maximum height less than 4.50 metres above the ground level may encroach into the front setback by 1.50 metres.
- Facade treatments and /or covered balconies or verandas on the second storey of a building that have a maximum height of less than 6.60 metres above ground level may encroach into the front setback by 1.50 metres.
- Porches, verandas, eaves, fascia, gutters and screens may encroach into the side and rear setback by 0.50 metres
- Domestic fuel tanks and water tanks may encroach into the side and rear setback by 0.50 metres
- Heating and cooling equipment and other services may encroach into the side and rear setback by 0.50 metres



MC MULLEN NOLAN GROUP
31/574 Plummer Street,
Port Melbourne, VIC, 3207
Tel: (03) 7002 2200
Fax: (03) 7002 2299
www.mngsurvey.com.au
MNG Ref : 80004be-046b

SCALE
1:500

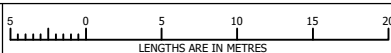

ORIGINAL SHEET
SIZE: A4

SHEET 4 OF 6

VERSION B

HARRIOTT
AT ARMSTRONG CREEK

SCHEDULE 1

HARRIOTT @ ARMSTRONG CREEK STAGE 5 BUILDING ENVELOPES

M.G.A. 2020 |
ZONE 55 |

SEE SHEET 4

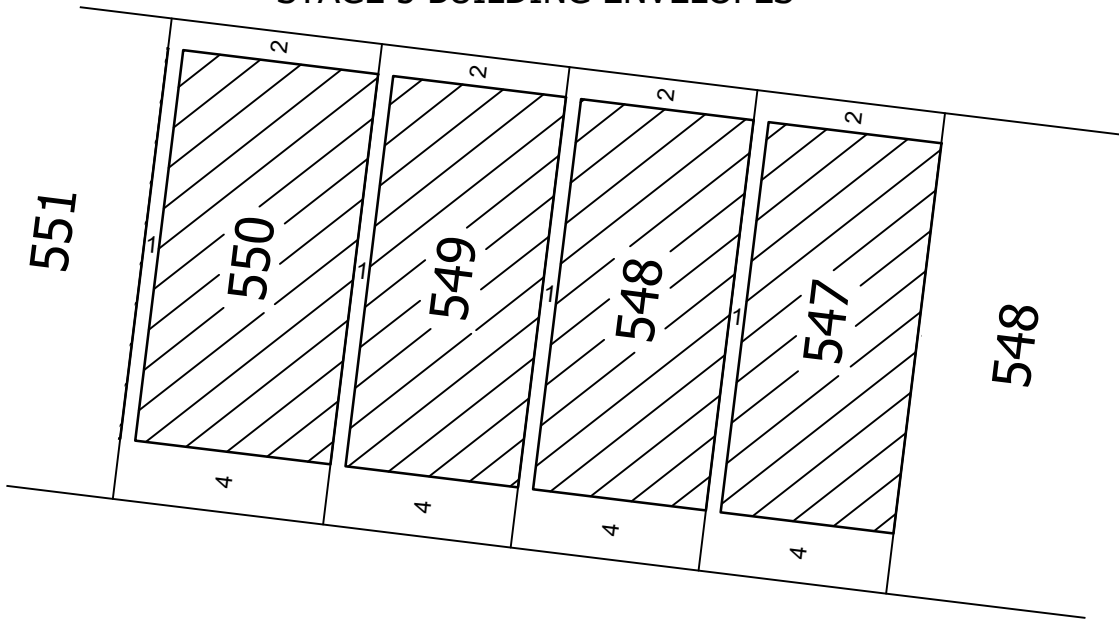

TRANQUILITY

CIRCUIT

SEE SHEET 6

532

527

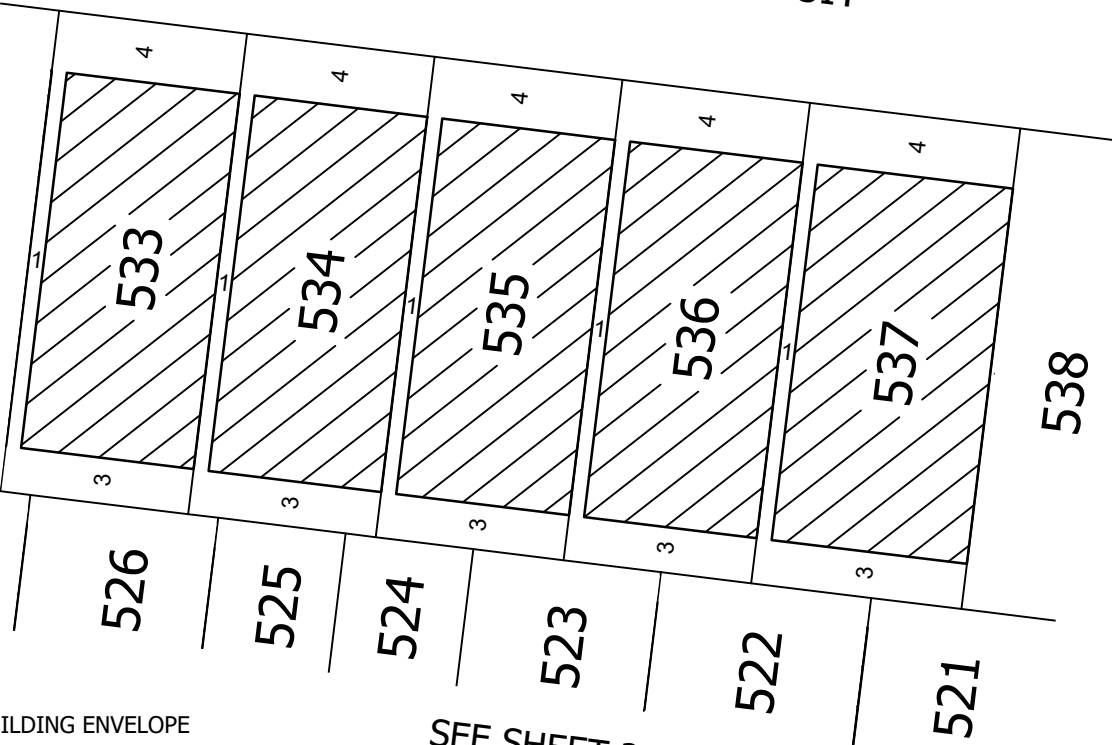

526

525

524

523

522

521

538

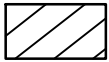

- BUILDING ENVELOPE

S

- SMALL LOT HOUSING CODE - TYPE A

SEE SHEET 2

- Garages are to be set back a minimum of 5 metres from the primary frontage of the allotment and 0.50 metres behind the front of the dwelling
- Balconies, verandas, open porches, covered walkways and porticos that have a maximum height less than 4.50 metres above the ground level may encroach into the front setback by 1.50 metres.
- Facade treatments and /or covered balconies or verandas on the second storey of a building that have a maximum height of less than 6.60 metres above ground level may encroach into the front setback by 1.50 metres.
- Porches, verandas, eaves, fascia, gutters and screens may encroach into the side and rear setback by 0.50 metres
- Domestic fuel tanks and water tanks may encroach into the side and rear setback by 0.50 metres
- Heating and cooling equipment and other services may encroach into the side and rear setback by 0.50 metres



MC MULLEN NOLAN GROUP
31/574 Plummer Street,
Port Melbourne, VIC, 3207
Tel: (03) 7002 2200
Fax: (03) 7002 2299
www.mingsurvey.com.au
MNG Ref : 80004be-046b

SCALE
1:500

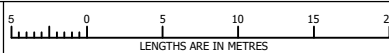

ORIGINAL SHEET
SIZE: A4

SHEET 5 OF 6

VERSION B

HARRIOTT
AT ARMSTRONG CREEK

SCHEDULE 1

HARRIOTT @ ARMSTRONG CREEK STAGE 5 BUILDING ENVELOPES

M.G.A. 2020 | ZONE 55 |

SEE SHEET 5

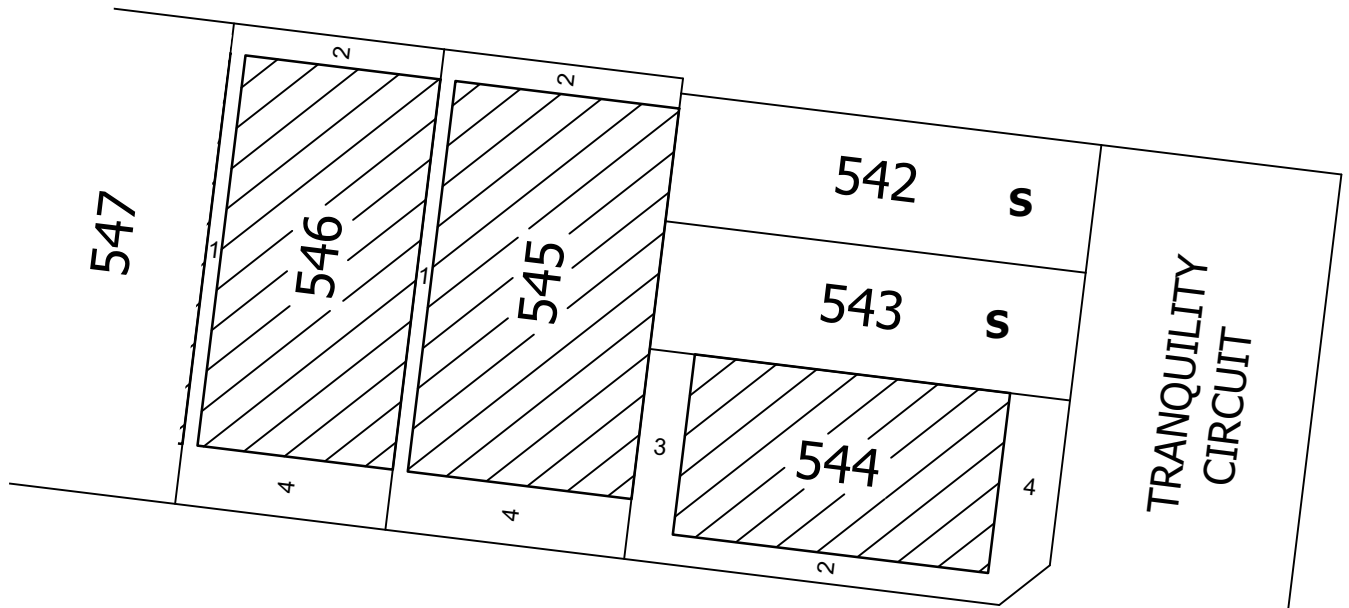

TRANQUILITY
CIRCUIT

TRANQUILITY
CIRCUIT

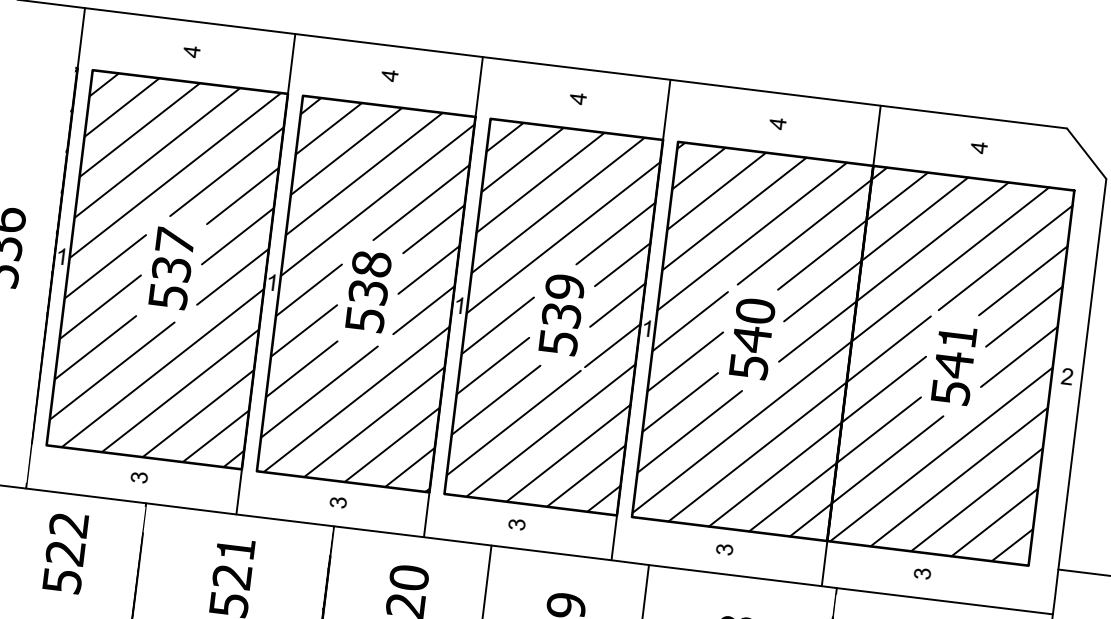

EURYBIA
PLACE

RESERVE No.1

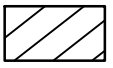

- BUILDING ENVELOPE

S

- SMALL LOT HOUSING CODE - TYPE A

SEE SHEET 1

- Garages are to be set back a minimum of 5 metres from the primary frontage of the allotment and 0.50 metres behind the front of the dwelling
- Balconies, verandas, open porches, covered walkways and porticos that have a maximum height less than 4.50 metres above the ground level may encroach into the front setback by 1.50 metres.
- Facade treatments and /or covered balconies or verandas on the second storey of a building that have a maximum height of less than 6.60 metres above ground level may encroach into the front setback by 1.50 metres.
- Porches, verandas, eaves, fascia, gutters and screens may encroach into the side and rear setback by 0.50 metres
- Domestic fuel tanks and water tanks may encroach into the side and rear setback by 0.50 metres
- Heating and cooling equipment and other services may encroach into the side and rear setback by 0.50 metres



MC MULLEN NOLAN GROUP
31/574 Plummer Street,
Port Melbourne, VIC, 3207
Tel: (03) 7002 2200
Fax: (03) 7002 2299
www.mngsurvey.com.au
MNG Ref : 80004be-046b

SCALE
1:500

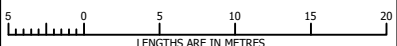

ORIGINAL SHEET
SIZE: A4

SHEET 6 OF 6

VERSION B

